

Balancing of Pulsed DC Air Ionizers Made Quick and Easy

Executive Summary The transient response of every CPM – pulsed ionizer system leads to balance measurements that appear to wander and appear to be unstable. A special delay mode in the Monroe 288B is designed to eliminate this issue and make pulsed DC ionizer setup quick and easy, saving maintenance time and is a very important addition to the calibration procedure.

Introduction Corona ionizers employ positive and negative high voltage to create the ions required to perform the discharge. The two voltages must be accurately adjusted so that the action of the ionizer is to discharge surfaces to 0 V rather than a non-zero voltage. An important function of the CPM is to adjust ionizer balance.

Ionizer Adjustment and Recommended Practice Documents The ESDA document STM 3.1 specifies that ionizer performance must be measured using a Charge Plate Monitor. It specifies the size of the plate, its capacitance to ground and the tests required to characterize the ionizer. The parameters to measure are discharge times (positive and negative) and its voltage balance.

In the case of a pulsed DC ionizer, the Standard Test Method defines peak offset voltage as the maximum plate voltage (both positive and negative). These voltages are called $+V_p$ and $-V_p$ by the Monroe CPM 288 series. A typical readout is shown in Figure 1.

While this is a perfectly valid measurement concept, the details of how a measurement is implemented in the CPM can make the ionizer appear unstable with repeated measurements. By using the Monroe CPM feature designed to eliminate the pitfall, adjustment becomes quick and easy.

The CPM and the Pulsed DC Ionizer The pulsed DC ionizer swings its voltage between a positive and a negative at a modest rate, driving the target object or the CPM plate, to 0 V. The CPM plate responds to the ionizer as a 20 pF capacitor connected to a resistor (the air column between the ionizer and the plate) and is driven from a voltage source which swings between a positive and a negative value, the ionizer. See Figure 2. The ionizer and CPM system respond just like a driven pendulum or a driven spring. Any of these start with some initial conditions and eventually achieve equilibrium. The dynamics of each can be predicted exactly and have been calculated for the ionizer-CPM system in Figure 2.

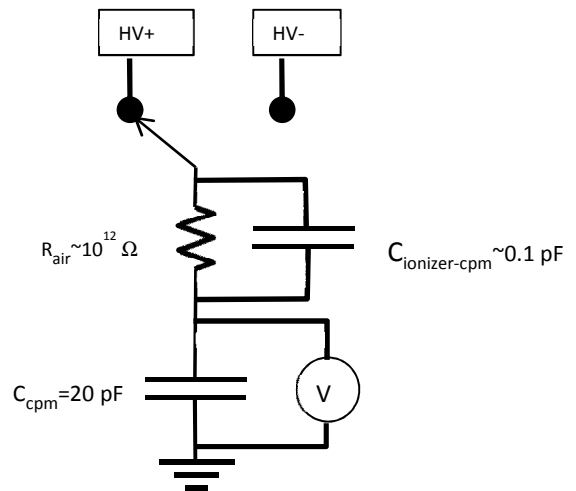

Figure 2. The Ionizer and the CPM.



Figure 1. The Monroe 288B measuring ionizer balance.

The ionizer discharge times were 10 s (1000 V to 100 V). The ionizer ON time was set to 3 s, the ionizer was balanced and the CPM was started exactly at the same time as the ionizer began a positive transition.

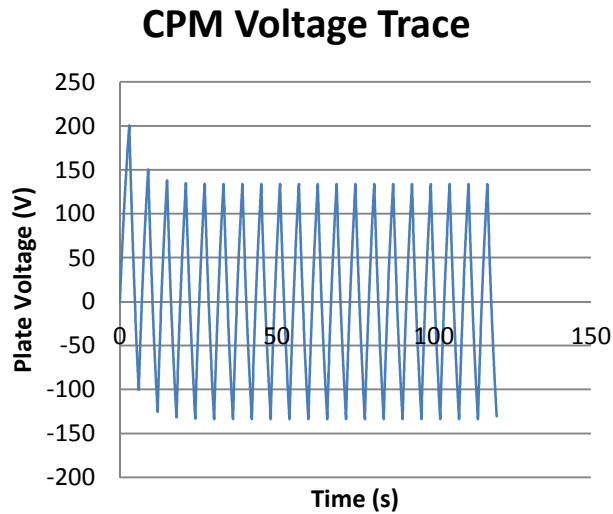

Figure 3. A CPM response with the ionizer in phase with the CP clock (Example 1)..

that shown in figure 3. The two traces end up with the same steady state response but have very different starting behavior. The action of a CPM in the Balance mode is to measure the Maximum Voltage, the Minimum

	Example 1	Example 2
Max Voltage (+V _p)	117.1 V	68.6 V
Avg Voltage	5.0 V	-5.0 V
Min Voltage (-V _p)	-68.6 V	-117.1 V

Table 1. CPM balance readout for the example in Figures 2 & 3.

Max Voltage is reported high due to the first few cycles of the waveform. In Example 2, the Min voltage is reported low for similar reasons. Both measurements do not reflect the actual operation of the pulsed DC

	Example 1	Example 2
Max Voltage (+V _p)	68.8 V	68.6 V
Avg Voltage	0.6 V	-0.6 V
Min Voltage (-V _p)	-68.6 V	-68.8 V

Table 2. CPM balance readout for the example in Figures 2 and 3 but excluding the first few cycles.

As can be seen in Figures 3, the first few cycles of the ionizer exhibit transient behavior and can be ignored since the eventual behavior of the system achieves equilibrium.

The ionizer's timing circuit is not connected to the CPM so the ionizer can have any phase relationship to the CPM clock. For example, if the ionizer were started 180 degrees later than the example in Figure 3, the CPM response would be as shown in Figure 4. The trace begins with transient response opposite to

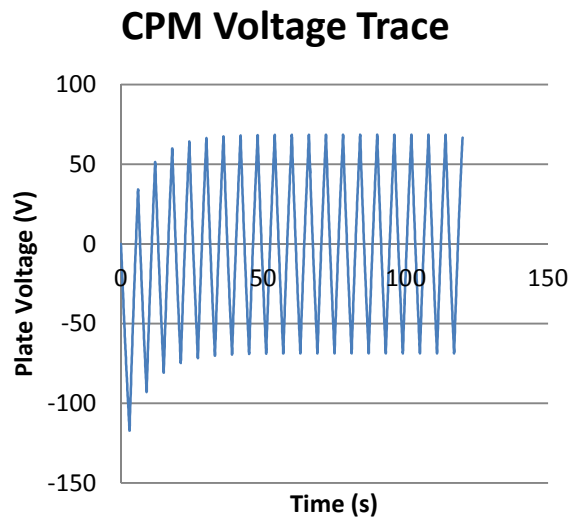

Figure 4. A CPM response with the ionizer 180 degrees out of phase with the CPM clock (Example 2).

Voltage and the Average Voltage over the measurement interval as specified by STM 3.1. Unfortunately, in the two cases above, the CPM would report very different values. See Table 1 for the CPM readings in both cases. In Example 1, the

ionizer.

The solution is simple. Delay the measurement until after the transient behavior is ended. If this delay is put into the measurement, the values of the measurement are shown in Table 2.

Using The Monroe 288B CPM Efficiently with a Pulsed DC Ionizer In order to correct for this anomaly, the Monroe 288B has a feature to allow the reset of the balance start

point of the time of the CPM analog acquisition to begin and then the digital calculation delayed by the user until the transient is over. The solution is simple. Separate the analog signal acquisition control from the digital data collection and analysis. To measure the balance of the ionizer with the 288B, the circuitry in the CPM starts to follow the ionizer swings. After a few seconds, the operator clears the $+V_p$, $-V_p$ and AVG settings from the display and digital acquisition restarts. This eliminates the confusion of digitizing the meaningless transient response of the CPM and only digitizes the steady state information as in Table 2.

When the 288B is put into the mode optimized for pulsed DC ionizers, it provides a reset control on the bottom menu. See Figure 5. The mode looks identical to the one in Figure 1 but a PkRst (peak reset) button appears at the bottom of the menu. This allows the operator to tell the instrument when the plate acquisition circuitry is beyond the transient response time and the readings become much more stable and the time to balance the ionizer becomes shorter. This can represent a substantial amount of time saved in a facility with many ionizers to balance.

Setting the Ionizer to the Pulsed DC Mode This is a simple operation. Simply select the setup menu (Man) from the main menu screen which appears at power on. Select Setup 1, 2 or 3. This allows all acquisition parameters to be set (Figure 6).

Set the Balance Duration to XXXXs which disables the balance time. As can be seen in the figure and then the unit will only reset when the PkRst (peak reset) menu button is pushed. Operation becomes simple. Enter the balance mode, wait of a few cycles of the ionizer as viewed on the CPM screen and then push PkRst. The balance readings will be stable and make good sense as compared with conventional CPMs which do not have this feature.



Figure 5. The CPM in the balance mode optimized for pulsed DC ionizer measurements.



Figure 6. Selecting the balance duration to be infinite.