

APPLICATION NOTE APNE-0016

Static Control in Web Converting

Table of Contents

- I. Continuous Measurement and Control of Web Static Levels in Critical Machine Areas2
 - Content.....2
 - Machine Grounding Hazard Elimination.....2
 - Machine Part Geometry Hazard Elimination.....2
 - Determining locations for continuous static control and monitoring in nonhazardous areas using portable fieldmeters.....3
 - Hints for maximum static control and effective monitoring3
 - Determining locations for continuous static monitoring in hazardous (flammable) areas.....3
 - Continuous tracking of fields in high-risk machine/product performance areas.....4
- II. Using Models 1036E and 1036F Electrostatic Fieldmeter Probes5
 - General5
 - Installation.....6
 - Servicing8
 - Intrinsic Safety (IS) Barriers11
- III. Principle of Operation11
- IV. References.....13
 - This Document13
 - General Fieldmeter References.....13
 - Useful Hazardous (Classified) Location and Intrinsic Safety References.....14
- V. Appendix A – Probe Connection Options15
 - General15
 - Constructing Your Own Cables.....17
- VI. Appendix B – Intrinsic Safety Barriers.....20
 - General20
 - Manufacturers of Approved IS Barriers.....20

I. Continuous Measurement And Control Of Web Static Levels In Critical Machine Areas

Content

Control of static is not something that occurs once and can then be forgotten. It requires the implementation of continuous procedures such as charge neutralization using ionizers and electric field monitoring using permanent fieldmeters to verify that the ionizers are working effectively. Antistatic measuring and control systems are needed in practice because the conditions for static elimination always change [1].

This document is the third in a series of three application notes about static charging of materials and equipment in web converting machines, including recommendations for static measurement, control, and continuous monitoring. The first document in the series is *APNE-0014 Electrostatic Charging In Web Converting* and the second is *APNE-0015 Electric Fields and Fieldmeters in Web Converting*.

This document provides the reader, working in either hazardous or non-hazardous areas, with the practical tools necessary to determine where permanent static control devices and Monroe Electronics Model 1036 fieldmeter probes should be mounted on web converting machines. This document includes installation and usage instructions for the 1036 probes.

The reader should first attempt to minimize web charging by becoming familiar with Application Note *APNE-0014 Electrostatic Charging In Web Converting* before proceeding with the recommendations in this document.

Machine Grounding Hazard Elimination

The most critical static control item to implement is electrical bonding and grounding of the web-processing machine. Unless intrinsically connected by virtue of construction (bolted together, gears with conductive grease, etc.), all conductive¹ parts on or near² the machine must be electrically bonded together [3]. The bonding wires or straps should then be electrically grounded on both sides of the bonding run to prevent electrical isolation of conductive components in case a bond breaks. Proper grounding and bonding need to be checked by an electrician at least yearly, and after any mechanical work is done on the machine.

Machine Part Geometry Hazard Elimination

Be careful to avoid incendive brush discharges³ from a charged web to conductive machine parts in hazardous areas due to part geometry. Brush discharges can occur in electric fields measured lower than 30 kV/cm at the web. These discharges are due to conductive protuberances or corners (e.g., those with an edge diameter of less than 10 mm) near the web, which concentrate the field to the 30 kV/cm breakdown strength of air [4].

¹ A part is considered conductive if it is metal, or exhibits a volume resistivity less than 10^6 ohm•cm [2].

² A charged web can charge an ungrounded conductor by induction, setting up a spark risk to another conductor, including a human body.

³ A discharge between a conductor and an insulator that is often characterized by crackling without sparking.

Determining Locations For Continuous Static Control And Monitoring In Nonhazardous Areas Using Portable Fieldmeters

To determine where static control devices and permanent static monitoring fieldmeter probes should be located, portable fieldmeters must first be used to determine the machine locations where fields are highest and need to be controlled (see *APNE-0015 Electric Fields and Fieldmeters In Web Converting*).

Passive and/or active ionizers (see Application Note *APNE-0014 Electrostatic Charging In Web Converting*) should be installed at the chosen locations and in the proper manner [3,5]. For high-speed or difficult-to-control operations, it may be necessary to install multiples of one or both type ionizers for complete static control.

Permanent fieldmeter probes (Monroe Model 1036E or 1036F) then need to be installed downstream of the static control device(s) in critical locations to monitor their effectiveness.

Hints For Maximum Static Control And Effective Monitoring

High-speed operations might require a second static neutralizer along the web between some rollers to sufficiently reduce the web charge.

For web materials thinner than 50mil, one ionizer and fieldmeter should be able to neutralize and measure both sides of web. For web materials thicker than 50mil, an ionizer and fieldmeter may be needed for both sides of web. The only way to know for sure is to install an ionizer on one side of the web, and then measure the residual field on both sides of the web. If the non-ionized side exhibits a higher field than the ionized side, then both sides require neutralization, measurement, and control.

If all proper spacing requirements can be met for web materials thinner than 50mils, the fieldmeter probes should be mounted with the measurement aperture facing downward. This is necessary to minimize foreign material entering the sensitive probe aperture.

For optimal performance, static eliminators need to be positioned using fieldmeters to obtain the lowest readings, both for distance from the web as well as distance from the previous roller. This can best be done using permanently installed fieldmeter probes after the eliminators.

Determining Locations For Continuous Static Monitoring In Hazardous (Flammable) Areas

As described in the section of this document *Machine Grounding Hazard Elimination* above, the most critical static control item to implement is effective grounding and bonding of conductive machine parts. Make sure conductive machine part shapes cannot also contribute to the static hazard problem by observing the recommendations in the section of this document, *Machine Part Geometry Hazard Elimination*. Then locate the general machine static monitoring positions as described in the section of this document *Determining Locations For Continuous Static Control And Monitoring In Nonhazardous Areas Using Portable Fieldmeters*.

Last, but most important, particular attention must be focused on the hazardous operations themselves. In a web converting process, these are usually flammable, solvent-based printing and other gravure operations, or coating, impregnating, and

spreading operations. Charge neutralization devices should be installed after the web roller just prior to the hazardous operation roller. Additional devices should also be installed after the hazardous operation roller, and after each drying and turning roller in the hazardous rated area [3]. The devices installed in hazardous locations need to be rated Intrinsically Safe for the atmosphere in which they are placed.

Permanent fieldmeters should then be installed after each charge neutralization device to monitor its performance and indicate when maintenance on it is required.

Permanent fieldmeters are especially necessary in hazardous areas to verify that nonhazardous web surface charge density levels are maintained. The probes are installed downstream of passive or active ionizers to ensure that the ionizers are operating correctly. This scenario assumes that all rollers but gravure and impression to be outside the classified area. All electrically powered equipment installed in these classified locations must be approved for the solvent atmosphere in which they are located, so both the fieldmeter probes and the ionizers must be approved for the classified areas in which they are installed.

In hazardous locations, it is recommended that backup fieldmeters be installed, in case the primary fieldmeter at that position fails. Typically, one probe is located about one-third of the way across the web, and the other probe is located about two-thirds of the way across the web, attached to the same mounting bracket.

Continuous Monitoring Of Fields In High-Risk Machine/Product Performance Areas.

Permanent Fieldmeter System. The Monroe Electronics Model 177A Static Monitor is a four-channel electrostatic fieldmeter. The Model 177A is the only system designed for long-term unattended monitoring of static levels in industrial environments. The Model 177A accepts up to four Model 1036E or Model 1036F electric-field-sensing probes. The probes measure the electric field in the particular locations where they are installed, and they continuously monitor for electric field levels that may indicate safety hazards or quality concerns. The probes can be mounted up to 1000 feet from the Model 177A. Probes should be air purged for long-term stability.

Choice of locations for the probes is critical. Locations should be chosen based on an understanding of machine/process performance. Handheld fieldmeters are used to help characterize the machine and select locations (see *APNE-0015 Electric Fields and Fieldmeters In Web Converting*). Fieldmeters located immediately following active or passive charge control devices (ionizers) monitor the effectiveness of the devices.

Zeroing needs to be checked at least monthly to compensate for drift of the zero point. Model 1036 probe calibrations should be checked yearly during routine machine maintenance shutdowns. Monroe Electronics provides this probe calibration service.

The Model 177A Static Monitor includes programmable output alarms. If static levels in your application exceed your defined values, a first-level alarm is triggered to warn about the elevated static levels. The process is allowed to continue at this first (warning) level. If the problem is rectified and static levels return to normal, the first-level alarm is extinguished and the static monitor returns to a normal state.

If the problem persists and if the static levels rise to exceed a second-level (crucial) alarm, a second-level alarm is triggered. The second level alarm signal(s) can be used to shut down the operation until it is brought under control, or to further warn the operator of the more serious condition.

Consult the Model 177A Operator's Manual for information about its features and operation. A full description of the operation of the Model 177A Static Monitor is contained in its operating manual. This information will not be repeated within this application note.

II. Using Models 1036E and 1036F Electrostatic Fieldmeter Probes

General

Models 1036E and 1036F electrostatic fieldmeter probes are electrically identical and interchangeable. The major differences are physical. Model 1036F is a small (1.75" dia. x 1.25" H), lightweight version for general-purpose applications, or where available space is a problem. Model 1036E, for most industrial applications, is a 1036F probe built into a standard Crouse-Hinds ½"-FS1 electrical box with a stainless steel cover.

Both probes utilize the same vibrating capacitor modulator, and both have built-in provisions for purging with filtered air to prevent contamination and long-term drift. Inert gas can also be used for purging in hazardous areas where the probe will be used in an inert gas atmosphere. Purge gas flow in the Model 1036F exits only through the sensitive aperture in the gradient cap⁴. Gas flow in Model 1036E is directed across the face of the gradient cap as well as through the sensitive aperture.

Typical applications are static level safety monitoring in flammable atmospheres, and static level quality monitoring in sensitive machine areas.



Figure II-1

Model 1036E Fieldmeter Probe



Figure II-2

Model 1036F Fieldmeter Probe

⁴ The gradient cap is the reference surface of the fieldmeter probe that contains the aperture and that faces the target surface during measurements.

Installation

Sensitivity

Full-scale sensitivity for any properly standardized and calibrated probe/instrument combination is dependent upon the gradient cap (containing the aperture) on each probe. The full-scale sensitivity for any given fieldmeter system or channel can be determined by inspecting the gradient cap on the probe. Each gradient cap is stamped on its face with a number that represents a different size aperture. This number is related to the sensitivity of the probe as shown in Table II-1 below. The probes are standardized at the factory in a uniform electric field. Once standardized in this manner, they may be interchanged at will.

Probe Model	Full Scale Sensitivity	
1036_-2	± 100 V/cm	(± 10 kV/M)
1036_-3	± 1 kV/cm	(± 100 kV/M)
1036_-4	± 10 kV/cm	(± 1 MV/M)
1036_-5	± 20 kV/cm	(± 2 MV/M)
1036_-6?	± 10 kV/in	Standard
1036_-7	± 1 kV/in	

Table II-1

Probe Model vs. Full Scale Sensitivity

Mounting

Probe mounting requirements for electrostatic field measurements will vary somewhat with the nature of the desired measurement. Whenever possible, mount the metric-reading probes from Table II-1 at one centimeter and the English-reading probes at one inch. When this is not possible, it is best to mount the probe as near as practical to the surface being monitored, as long as the input signal remains less than the full-scale sensitivity of the probe. It is strongly recommended that the probe be mounted "looking" downward in order to minimize the probability of contaminants entering the aperture in the face.

Model 1036E is provided with two mounting flanges that accommodate ¼" bolts or screws. The case should be electrically connected to ground. The gradient cap (containing the aperture) of the probe is a reference surface with its own ground connection. Do not make a separate ground connection to this surface.

Model 1036F may be held by hand to make rough measurements, or mounted by means of two threaded inserts in the back plate of the probe. Care must be exercised when selecting screw length. These are blind holes with a depth of 0.089". They will accommodate up to five full #4-40 threads. Some additional, temporary mounting options are friction clamps, adhesives, or double-sided tape. The metal body of the

probe is internally connected to instrument ground and should not normally be connected to any other ground.

Geometry

A shroud⁵ is not necessary on 1036E probes mounted at one inch or less from the web because the large faceplate provides the same function as a shroud (creates a uniform electric field in front of the probe at one inch or less). For more information about shrouds, see Application Note *APNE-0003 Fieldmeter Measurement Techniques Using Monroe Electronics Model 1036 Probes*.

As a truly uniform field does not usually occur in most practical measurement situations using the 1036F probes, partly due to the introduction of the grounded probe itself, one must either:

- Improve the geometry by establishing a grounded plane (shroud) through which the fieldmeter probe can “view” the target surface,
- Establish a correction factor for the data, or
- Accept relative data. In many cases, this is an acceptable practice once a fixed geometry is established and that data is related to the real electric field.

Cables:

Both Models 1036E and 1036F probes are normally equipped with 10-foot-long cables and subminiature D connectors, which mate with the Monroe Electronics Model 177A Static Monitor. This is Option 1 of six available wiring options. See Appendix A – Probe Connection Options for details. The first three options are for non-hazardous (non-classified) locations where there are no Intrinsic Safety (IS) considerations. The last three options are for hazardous (classified) locations where Intrinsic Safety must be considered as part of the installation.

Extension cables are available from Monroe Electronics in lengths up to 1000 feet, which is the maximum permissible length. These cables may be ordered in any length (up to 1000 feet) by part number 1036/12-*nnnn*, where *nnnn* is the length in feet.

The cable exit on the Model 1036E is through a packing gland that is screwed into a ½"-14 NPT tapped hole in a boss on one end of the housing. Inside the housing, the probe is plugged into a terminal block to which the cable attaches. Where it is desirable or necessary to connect Model 1036E probes to Model 177A Static Monitors using conduit, the original cable and packing gland can be removed and the cable replaced by any length (up to 1000 feet) pulled through the conduit. Refer to Appendix A – Probe Connection Options, Options 3, 4 or 6 (depending on whether Intrinsic Safety must also be considered) for details, including wiring information.

Purging

Any contamination present in the probe or near the measurement will have an adverse affect on performance. When insulative particulate or liquid becomes charged and enters the probe or attaches near the aperture of the probe, it becomes a source of measurement error and drift. Less obvious is the influence of gaseous

⁵ A shroud in this instance is a grounded surface in the plane of the gradient cap. For more information about shrouds, see Application Note *APNE-0003 Fieldmeter Measurement Techniques Using Monroe Electronics Model 1036 Probes*.

atmospheric constituents, including aerosols, which contaminate the probe by altering the contact potentials⁶ between critical surfaces.

Constant purging of the Model 1036 probe with clean dry air or an inert gas is recommended whenever practicable to prevent airborne contaminants from entering the aperture in the gradient cap and being deposited on the electrode.

The air supply should meet standard *ANSI/ISA-7.0.01-1996 - Quality Standard for Instrument Air*. A Koby "Junior" filter available from Koby, Inc., 299 Lincoln Street, Marlboro, MA 01752 should meet this standard and will provide sufficient mechanical and chemical filtration for up to four probes under most conditions.

A complete probe purge kit, Model 1017/22G, is available for the Model 1036F from Monroe Electronics. It includes a low volume, long-life air pump, mechanical and chemical filters, and a supply of tubing. The pump is fully capable of 24-hour-per-day operation, thus keeping the probe ready for immediate use. A purge gas inlet tube supplied with each 1036F probe may be installed in either of two positions, the choice of which is primarily a matter of convenience in routing of the hose carrying the purge gas. These consist of tapped holes that exit at 90° to each other near the probe cable. If it is desired to move the purge tube to the other location, simply switch the purge tube with the Allen set screw plugging the other hole.

Purge the Model 1036E probe through a ¼"-18 NPT tapped hole in the end of the housing near the cable exit using common plumbing or tubing components.

Gas pressure to either probe type should be only great enough to produce a slight positive flow out of the probe and in no event should it exceed a pressure of ½ psi.

Servicing

General

It must be emphasized that the critical elements of these probes (gradient cap and sensing electrode) must be kept free from contaminants, e.g., dust, fumes, mists, or any foreign material. The materials of which these elements are made were very carefully chosen to minimize contact potential. Any foreign matter that will cause relative electrical activity when combined with relative motion will tend to cause drift and measurement errors.

Therefore, it is recommended that:

- Probes be constantly purged even when not in use, if this is practical.
- Probes be kept tightly covered when not in use and are not being purged to prevent contamination. A covering such as a plastic bag or aluminum foil may be used. DO NOT cover the sensitive aperture with adhesive tape.
- Probes be cleaned only to the degree and frequency necessary to achieve the required stability.
- Gradient caps NOT be removed for cleaning unless absolutely necessary.

⁶ Contact potential between two conductors is caused by their different work functions, which are the energies needed to remove an electron from the conductor. This gives rise to a potential (voltage) difference. This energy is affected by the properties of the surface region. Thus, the work function is very sensitive to surface conditioning, contamination, etc.

- Major cleaning and reconditioning be performed by the factory.

Cleaning

The recommended cleaning solvent is clean 70-100% isopropyl alcohol applied with a suitable soft, lint-free applicator. Use of a non-approved solvent may degrade performance permanently, requiring factory service.

Outside surfaces of the probe should first be wiped clean with a lint-free wiping tissue saturated in solvent. Then the interior surfaces should be flushed with solvent, using a plastic squeeze bottle⁷, through the aperture until no dirt or dust may be seen. The probe should then be allowed to drain and dry thoroughly. A 15-minute bake-out at 75°C is recommended to remove residual solvent.

Model 1036E Disassembly/Assembly

In order to rewire the cable terminal block, replace, or standardize the probe assembly, it must first be removed from its housing. This is done by loosening the four crosspoint screws around the outer edge of the cover 1-1½ turns each, in turn, several times while lifting the cover and probe straight out of the housing until it is completely removed. **DO NOT** attempt to remove the screws completely one at a time. These four screws have circular "E-rings" installed on them under the cover plate to make the screws captive and prevent their falling into machinery below.

The probe assembly will need to be removed from the cover plate on the bench for standardization, calibration, or to replace the gradient cap. This is done by removing the four crosspoint screws that secure the phenolic mounting block to the hex standoffs, leaving the standoffs attached to the cover plate.

To reassemble the probe unit, essentially reverse the above procedure. Once the phenolic mounting block has been secured to the four hex standoffs, the probe unit should be inspected to assure that an even gap exists completely around the gradient cap between the gradient cap and the cover plate. If not, loosen the two crosspoint screws that secure the probe body to the phenolic mounting block, and adjust the probe body so that it is centered and completely surrounded by an even air gap.

Partially mate the card-edge fingers into the terminal block connector in the housing and tighten the four outer screws in the cover plate 1-1½ turns at a time until the assembly is secured in the housing.

Standardization

A simple, accurate means of standardizing Model 1036 probes using any channel of the Model 177A Static Monitor is given here.

The primary reason for standardization of Model 1036 probes is to assure interchangeability of probes. The procedure is not suggested as routine, but is presented here in the event it becomes necessary to re-standardize following replacement of a gradient cap or major probe overhaul. It should be performed only under controlled conditions in a suitably equipped electronics laboratory.

All Model 1036 probes are shipped from the factory standardized in a uniform (parallel) field. The calibration fixture consists of two flat rigid metal plates that are

⁷ Soft plastic wash bottles with an attached nozzle are available from scientific supply distributors.

parallel and separated with insulators by a distance "d" of one inch and have side dimensions of at least 5d (the bigger, the better; within practical limitations). Refer to Figure II-2 for a description of this fixture and the calibration method.

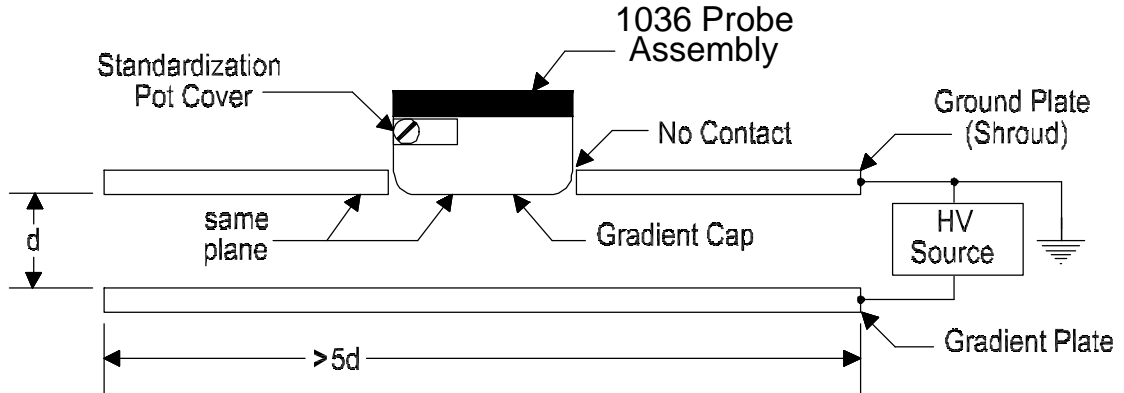

Figure II-2

Standardization Fixture (P.N. 96102A) Setup for 1036 Probes

The ground plate has a hole in its center just large enough to provide clearance around the probe so that the probe does not make contact with the plate. A calibrating voltage is applied to the gradient plate of the fixture to establish a reference field in the volume between the plates. This fixture is available from Monroe Electronics, Inc. as part number 96102A.

A Probe Standardization/Test Cable, Monroe Electronics model number 1036/22C, is required to standardize or bench-test Model 1036E probes. No special cable is required for Model 1036F probes.

The standardization procedure is as follows:

- Set up the apparatus as outlined above. Set a precision calibrating voltage source to zero volts.
- Set the Model 177A Static Monitor zero control of the selected channel to read a value of 0.000 at its analog output using a high-quality digital multimeter (DMM).
- Table II-2 lists the precision high voltage (V_{HV}) source requirements for standardization of the various probes. Apply the calibrating source voltage (V_{HV}), as shown in Table II-2, for the probe model being calibrated.
- Adjust the calibration potentiometer in the probe to produce value (V_{IND}), as shown in Table II-2, at the analog output of the selected channel using the same DMM as above.

Probe Model	Sensitivity	V _{HV}	V _{IND}
1036_-2	±100 V/cm	254 V	100.0 V
1036_-3	±1 kV/cm	2540 V	1.000 kV
1036_-4	±10 kV/cm	2540 V	1.00 kV
1036_-5	±20 kV/cm	2540 V	0.50 kV
1036_-6	±10 kV/in	1000 V	1.000 kV
1036_-7	±1 kV/in	1000 V	1.00 kV

Table II-2

HV Source and Meter Reading for Probe Standardization

Intrinsic Safety (IS) Barriers

Model 1036E and 1036F Electrostatic Fieldmeter Probes meet Factory Mutual Research Corporation requirements for Class I, Division 1, Groups C and D hazardous locations when installed in accordance with the appropriate Monroe Electronics, Inc. control drawings. To comply, approved safety barriers must be used as shown in these control drawings. These drawings are included in Appendix B – Intrinsic Safety Barriers, in the Model 177A Instruction Manual that is shipped with the instrument, or are available from Monroe Electronics.

Copies of the Factory Mutual Research Corporation report 1Q3A9.AX, specific to these probes, are available on request from:

Monroe Electronics, Inc.
100 Housel Avenue
Lyndonville, NY 14098
Tel. (716) 765-2254, Fax. (716) 765-9330

III. Principle of Operation

Refer to Figure III-1 for the following discussion.

The probe is placed to “view” the target surface, which is assumed to be charged. In this instance, the gradient cap containing the aperture faces the target surface.

A sensitive electrode behind the aperture is vibrated perpendicular to the electric field by means of a drive coil (vibrated toward and away from the target surface). An A.C. signal is induced onto the sensitive electrode due to the motion of the vibrating electrode in the electric field, which is created by the charges on the target surface. The modulation amplitude of the A.C. signal, relative to the drive coil signal, is related to the polarity of the charge on the target surface.

This A.C. signal, conditioned by a preamplifier, filter, and signal amplifier, is fed into a phase-sensitive demodulator. This signal from this demodulator feeds an integrating amplifier. A fraction of the integrator's output signal is fed back to the sensing electrode to null the signal from the external electric field.

The voltage signal from the integrator is thus directly proportional to the field intensity at the sensing electrode of the probe. The output signal from the integrator drives a meter for direct readout.

The fieldmeter gives a reading of the field intensity at any spacing. If the spacing is known, the voltage on the target surface can be determined.

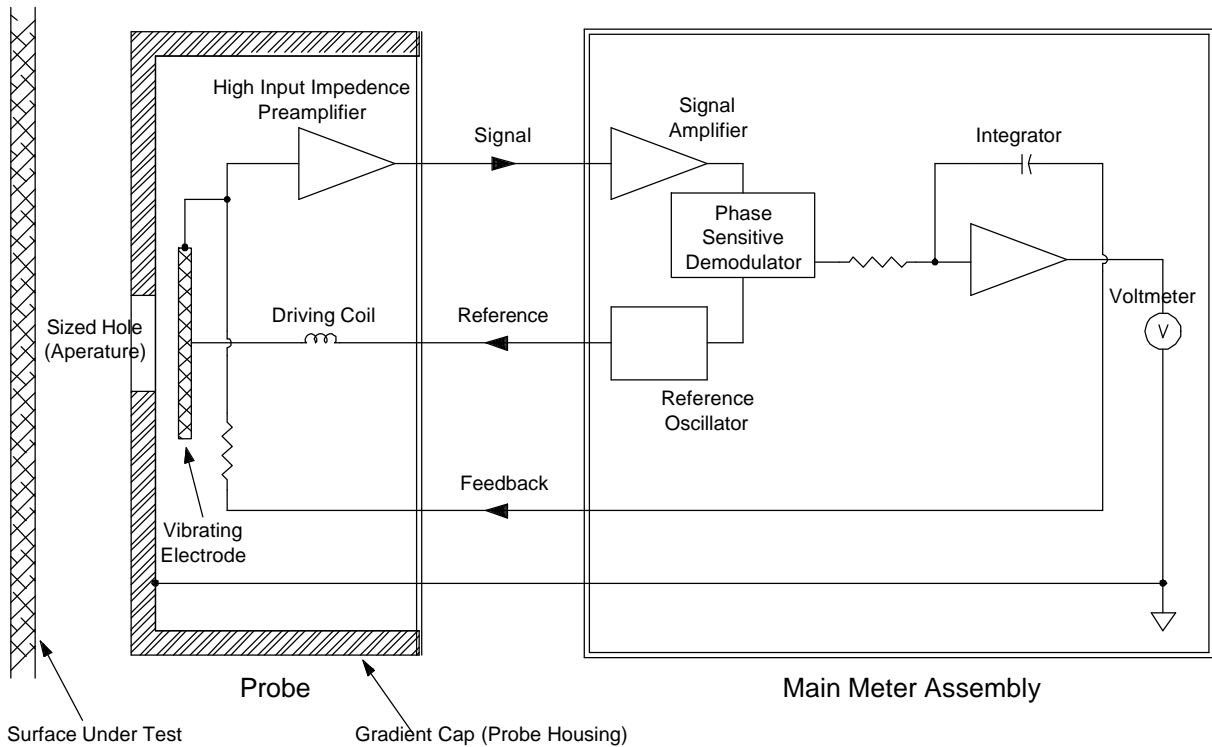

Figure III-1

Simplified Block Diagram for an Electrostatic Fieldmeter

IV. References

This Document

- [1] Horváth, T. and Berta, I., *Static Elimination*, Research Studies Press, Chichester (1982).
- [2] *ESD STM11.12-2000: Volume Resistance Measurement of Static Dissipative Planar Materials*, ESD Association, Rome, NY (2000)
- [3] *NFPA 77: Recommended Practice on Static Electricity*, 2000 Edition, National Fire Protection Association, Quincy, MA (2000).
- [4] Walmsley, H.L., "Avoidance of Electrostatic Hazards in the Petroleum Industry", *J. Electrostatics*, Vol. 27, No. 1 & No. 2, Elsevier, New York (1992)
- [5] TANTEC Static Elimination Guidebook, *A Guidebook On Using Electrostatics For the Elimination of Static Charges on Industrial Surfaces*, Schaumburg, IL (1998)

General Fieldmeter References

The following references are available from Monroe Electronics, Inc.

"Standards Related to Static Electricity", www.monroe-electronics.com/esd_appntspdf/apne-0001.pdf

"Fieldmeter Measurement Techniques Using Monroe Electronics Model 1036 Probes", www.monroe-electronics.com/esd_appntspdf/apne-0003.pdf

WILLIAM E. VOSTEEN, Monroe Electronics, Inc., "A Review of Current Electrostatic Measurement Techniques and their Limitations" Presented at the ELECTRICAL OVERSTRESS EXPOSITION, April 24-26, 1984.

LT 18: MARK BLITSHTEN, The Simco Company, Inc., "Measuring the Electric Field of Flat Surfaces with Electrostatic Fieldmeters" Presented at the ELECTROSTATIC SOCIETY OF AMERICA CONFERENCE ON ELECTROSTATICS, June 20-22, 1984.

LT 21: R.G. CUNNINGHAM, Eastman Kodak Co., "Use of Fieldmeters for Charge Measurements on Moving Webs" in 1975 ANNUAL REPORT. CONFERENCE ON ELECTRICAL INSULATION AND DIELECTRIC PHENOMENA, NATIONAL ACADEMY OF SCIENCES pp. 13-20, 1978.

LT 22: A. VAN ROGGEN, E.I. du Pont de Nemours & Company, "The Use of Electric Field Meters for Precision Measurements" in 1972 ANNUAL REPORT. CONFERENCE ON ELECTRICAL INSULATION AND DIELECTRIC PHENOMENA, NATIONAL ACADEMY OF SCIENCES, pp. 9-16, 1973.

LT 25: Monroe Electronics, Inc., "Guide to Monroe Electronics Electrostatic Fieldmeters"

Useful Hazardous (Classified) Location and Intrinsic Safety References

American National Standards Institute (ANSI) and International Society for Measurement and Control (ISA)

ISA-12.00.01-1999 (IEC 60079-0 Mod)

Electrical Apparatus for Use in Class I, Zones 0 & 1 Hazardous (Classified) Locations - General Requirements

ISA-12.01.01-1999

Definitions and Information Pertaining to Electrical Instruments in Hazardous (Classified) Locations

ISA-12.02.01-1999 (IEC 60079-11 Mod)

Electrical Apparatus for Use in Class I, Zones 0, 1, & 2 Hazardous (Classified) Locations - Intrinsic Safety Requirements

ANSI/ISA-RP12.6-1995

Wiring Practices for Hazardous (Classified) Locations Instrumentation Part I: Intrinsic Safety

ANSI/ISA-TR12.24.01-1998 (IEC 79-10 Mod)

Recommended Practice for Classification of Locations for Electrical Installations Classified as Class I, Zone 0, Zone 1, or Zone 2

ISA

PO Box 12277, 67 Alexander Drive
Research Triangle Park, NC 27709

Telephone: 919-549-8411

Fax: 919-549-8288

E-Mail: info@isa.org

National Fire Prevention Association (NFPA)

NFPA 34:

Standard for Dipping and Coating Processes Using Flammable or Combustible Liquids

NFPA 77:

Recommended Practice on Static Electricity

NFPA 325:

Guide to Fire Hazard Properties of Flammable Liquids, Gases, and Volatile Solids

NFPA 497:

Classification of Flammable Liquids, Gases, or Vapors and of Hazardous (Classified) Locations for Electrical Installations in Chemical Process Areas

Electrical Installations in Hazardous Locations

National Fire Protection Association

1 Batterymarch Park

PO Box 9101

Quincy, MA 02269-9101

Tel: (800) 344-3555

V. Appendix A – Probe Connection Options

General

Model 1036E or 1036F Probes may be wired to the Model 177A Static Monitor in at least six different ways. The first 3 options are for non-hazardous (non-classified) locations where there are no Intrinsic Safety (IS) considerations. The last 3 options are for hazardous (classified) locations where Intrinsic Safety must be considered as part of the installation.

Option 1: Probes (1036E or 1036F) use factory installed cables; no extension cables; no Intrinsic Safety considerations

Probes are normally factory equipped with ten-foot-long cables, although longer or shorter cables are available on special order. To use or test this system, simply plug the probes into the appropriate connectors on the back of the Model 177A.

Option 2: Probes (1036E or 1036F) use factory installed cables and factory supplied extension cables; no Intrinsic Safety considerations

Extension cables are available in lengths up to 1000 feet. The extension cable part number is *1036/12-nnnn*, where *nnnn* denotes the length of the cable in feet. Factory supplied extension cables will be labeled with this part number near one end.

The extension cable female connector mates with the 1036 probe cable male connector, and the extension cable male connector mates with the female connector on the back of the Model 177A.

Although it is virtually impossible to err, it is advisable to test the system "on the bench" before permanently installing long cable runs.

Option 3: 1036E probes with long customer installed cables, with or without extension cables (factory or customer supplied); no Intrinsic Safety considerations

This option does not apply to 1036F probes, which have permanently attached cables.

Wiring connections for customer installed 1036E probe cables for use in a non-IS installation are shown in Figure V-1. Wiring connections for customer supplied extension cables for use in a non-IS installation are shown in Figure V-2. Model 1036E probes have terminal blocks inside their housings to which the cable wires are directly attached.

As in Option 2, it is advisable to "bench test" the system before removing the factory-attached cables to ensure it is working properly. It is also advisable to test the system "on the bench" after attaching the customer-installed cables, with any extension cables, before permanently installing long cable runs.

Option 4: 1036E probes with factory installed cables, extension cables (factory or customer supplied) and Intrinsic Safety barriers

Refer to drawing 1036/10 [SHT. 2 of 3] in the Model 177A Instruction Manual. This drawing shows wiring for one channel. Generally, all channels are wired alike. All barriers (four per channel) may be located in a single barrier enclosure.

Note that (on each side of the barrier enclosure) you have the option of using connectors or "hard wiring" the cables directly to terminals on each barrier. Hard wiring allows the cables to be pulled through conduit without interference associated with connectors. Model 1036E probes have terminal blocks inside their housings to which the cable wires are directly attached. Wiring details for customer supplied extension cables are shown in Figure V-2.

As in the previous options, it is advisable to test the system "on the bench" after attaching the customer installed cables, with any extension cables, before permanently installing long cable runs.

Option 5: 1036F probes with factory installed cables, extension cables (factory or customer supplied) and Intrinsic Safety barriers

Refer to drawing 1036/10 [SHT. 3 of 3] in the Model 177A Instruction Manual. This drawing shows wiring for one channel. Generally, all channels are wired alike. All barriers (four per channel) may be located in a single barrier enclosure.

Note that (on each side of the barrier enclosure) you have the option of using connectors or "hard wiring" the cables directly to terminals on each barrier. Hard wiring allows the cables to be pulled through conduit without interference associated with connectors. Wiring details for customer supplied extension cables are shown in Figure V-2.

As in the previous options, it is advisable to test the system "on the bench" after attaching the extension cables before permanently installing long cable runs.

Option 6: 1036E probes with customer installed cables, extension cables (factory or customer supplied) and Intrinsic Safety barriers

Refer to drawing 1036/10 [SHT. 1 of 3] in the Model 177A Instruction Manual. This drawing shows wiring for one channel. Generally, all channels are wired alike. All barriers (four per channel) may be located in a single barrier enclosure.

Note that (on each side of the barrier enclosure) you have the option of using connectors or "hard wiring" the cables directly to terminals on each barrier. Model 1036E probes have terminal blocks inside their housings to which the cable wires are directly attached. Hard wiring allows the cables to be pulled through conduit without interference associated with connectors. Wiring details for customer installed 1036E probe cables are shown in Figure V-1. Wiring details for customer supplied extension cables are shown in Figure V-2.

It is advisable to "bench test" the system before removing the factory-attached cables to ensure it is working properly. As in the previous options, it is advisable to test the system "on the bench" after attaching the customer installed cables, with any extension cables, before

permanently installing long cable runs.

Constructing Your Own Cables

There are a couple of reasons why you may want to construct your own cables:

1. To save money.

You may be able to save money if everything goes OK. However, troubleshooting may prove to be more costly in the end than using factory supplied cables.

2. Conduit must be used for cable runs, but cable connectors won't fit through conduit you normally use.

The largest rectangular cross sectional dimensions of each connector are 1" x 1¼". The minimum conduit ID through which this can be pulled is 1 1/8". However, it is possible, with a great deal of care, to pull up to five cables simultaneously through that ID in a smooth straight run by staggering the connectors.

There are a couple different approaches for constructing your own cables to fit through your conduit:

1. Buy factory extension cables and modify them.

Cable construction details for 1036E probes with customer installed cables are provided in Figure V-1. This option does not apply to 1036F probes, which have permanently attached cables.

Extension cables are available in lengths up to 1000 feet. The extension cable part number is 1036/12-*nnnn*, where *nnnn* denotes the length of the cable in feet. Factory supplied extension cables will be labeled with this part number near one end. The cables need to be long enough to reach from the console location, through the conduit, and to the probe location with a few feet extra for measurement error.

Remove and discard the factory supplied (usually ten-foot) cable from the probe (Model 1036E only), and mount the probe housing at the measurement location.

Cut the female DB9 connector plug off the extension cable.

Pull the cable from the IS Barrier and/or Model 177 instrument end of the conduit to the probe end.

2. Buy bulk cable and connect both ends manually.

Cable construction details for 1036E probes with customer installed cables are provided in Figure V-1. This option does not apply to 1036F probes, which have permanently attached cables.

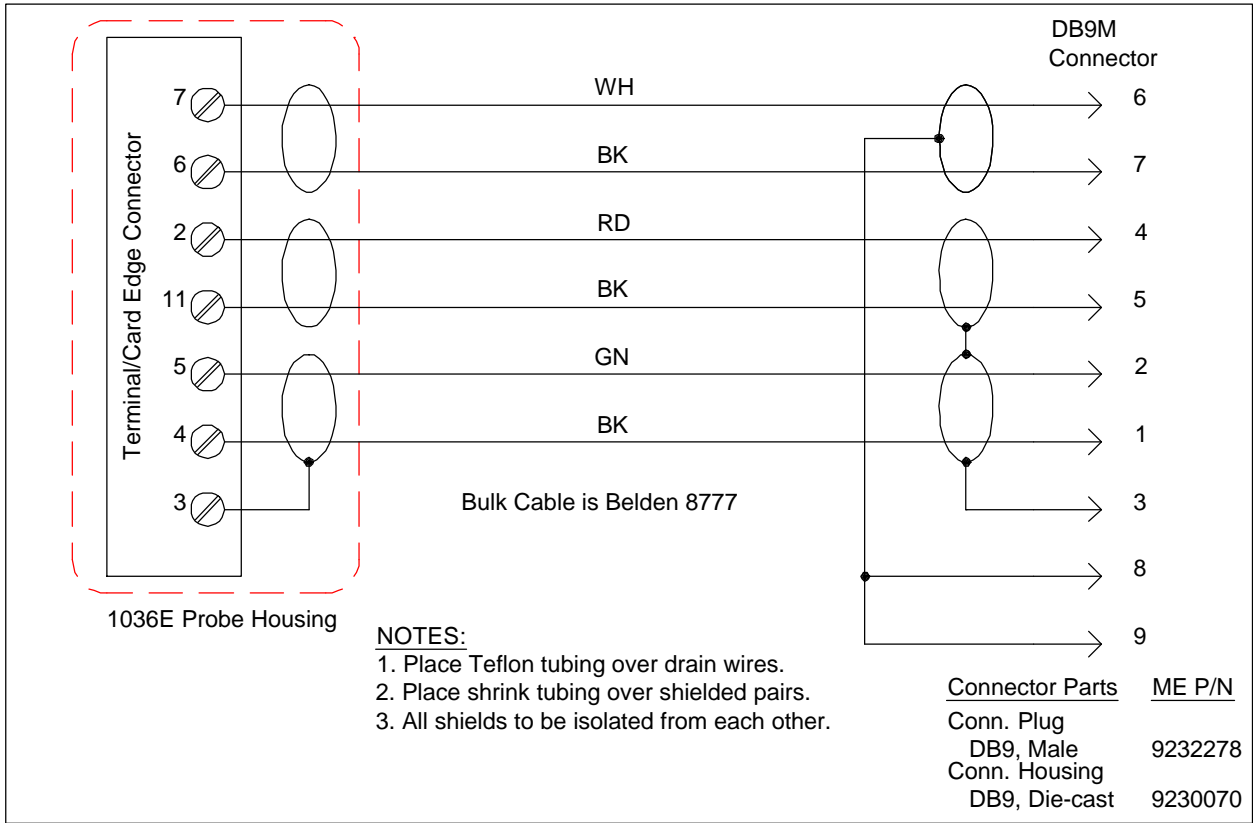

Figure V-1
1036E Customer Installed Cable

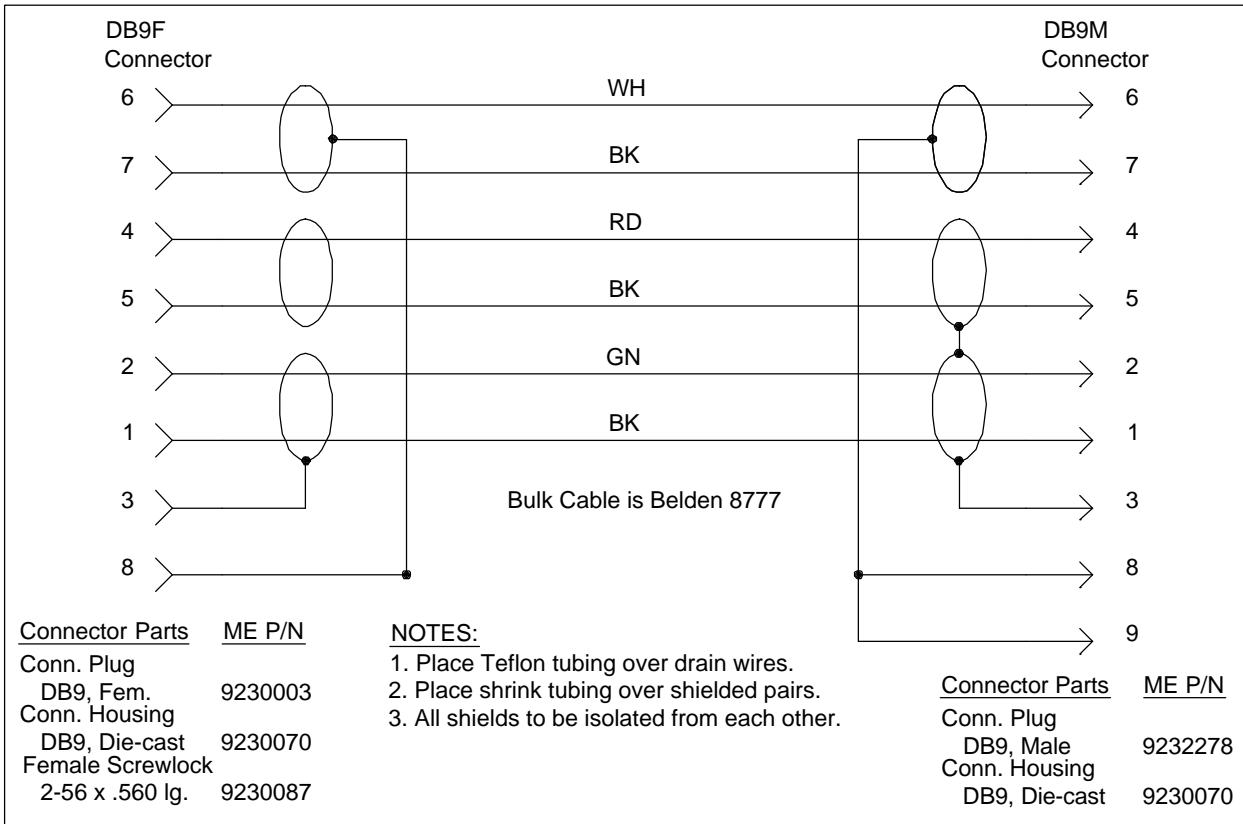

Figure V-2

1036 Customer Installed Extension Cable

VI. Appendix B – Intrinsic Safety Barriers

General

Model 1036E and 1036F Electrostatic Fieldmeter Probes meet Factory Mutual Research Corporation requirements for Class I, Division 1, Groups C and D hazardous locations when installed in accordance with the appropriate Monroe Electronics, Inc. control drawings included in this document. Approved safety barriers must be used as shown in the drawings to comply.

Copies of the Factory Mutual Research Corporation report 1Q3A9.AX specific to these probes are available on request from:

Monroe Electronics, Inc.
100 Housel Avenue
Lyndonville, NY 14098
Tel. (716) 765-2254
Fax. (716) 765-9330

Manufacturers of Approved IS Barriers

Two manufacturers of IS barriers are currently approved:

MTL, Incorporated	and	R. Stahl, Inc.
8576 Wellington Road		150 New Boston St.
PO Box 1690		Woburn, MA 01801-6204
Manassas, VA 22110-1690		
Tel. (703) 361-0111		Tel. (617) 933-1844
Fax. (703) 368-1029		Fax. (617) 933-7896

Barrier requirements and recommended enclosures are shown in the tables below:

MTL Barriers and Enclosures

Number of Channels	1	2	4	6	8	10	12	14	16
	Number of Barriers								
MTL 765	2	4	8	12	16	20	24	28	32
MTL 766	2	4	8	12	16	20	24	28	32
	Recommended Enclosures								
MT 5	1								
MT 12		1							
MT 24			1	1		2	2		
MT 32					1			2	2

Table VI-1

Notes for MTL Systems:

Enclosures include barrier mounting hardware, tagging strips, etc. Labeled wiring ducts are included with MT 32.

Listed enclosures are glass-filled polycarbonate with transparent lids. They are impact resistant, flame retardant and dustproof to IEC529:IP65.

MTL will install barriers at no charge if supplied with position (sequence) information.

"Internals" (everything that normally goes in an enclosure but no enclosure) are available.

R. Stahl Barriers and Enclosures

Number of Channels	1	2	4	6	8	10	12	14	16
	Number of Barriers								
9002/77-150-300-00	2	4	8	12	16	20	24	28	32
9002/22-240-160-00	2	4	8	12	16	20	24	28	32
	Recommended Enclosures								
S 806 NF-12	1	1							
S 1412 NF-25			1	1					
S 1412 NF-50					1	1	1		
S24H20BLP-80								1	1

Table VI-2

Notes for R. Stahl Systems:

Enclosures include mounting rails, insulating standoffs, ground terminals and labels.

Listed enclosures are Hoffman NEMA-4.